

HLV304M

**Custom-made
design
available!**

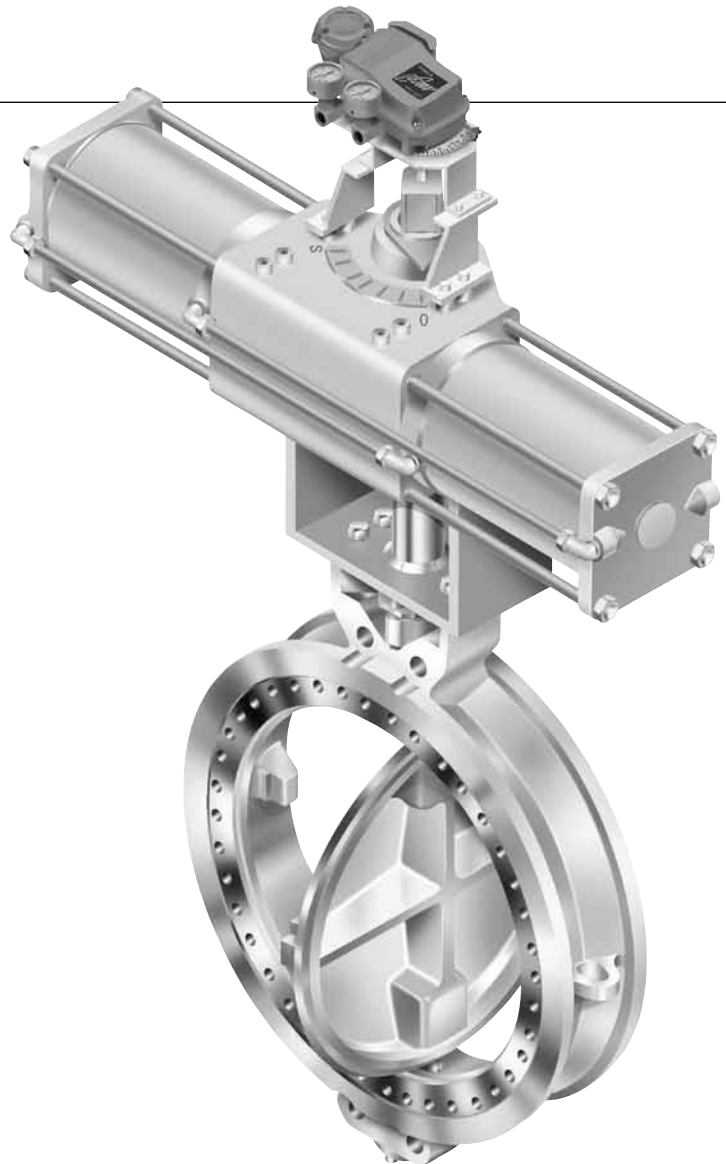

Characteristics

Suitable for high-temperature, medium-to low- pressure service, such as in hot air, exhaust gas, steam, chemical fluids, and solvents.

Compact Design

Short pattern face to face dimensions. The body and disc design contributed to a valve that is lower in weight and more compact than other valves of this type.

Double Offset Geometry

The axis of disc rotation is double offset to the seat. When the disc rotates, it unseats at a small turning angle by its cam effect. This prevents seat wear and provides reliable sealing performance over a long period.

Simple Sealing Design/Reliable Performance

The simple sealing design with a minimal number of parts allows easy maintenance without special tools. Tight shut off with an RPTFE seat is available. See PT rating chart.

Custom-Made Design

Custom made designs, including the use of special materials, a double flanged body or special face to face dimensions are available upon request. A metal seat type is also available.

304M PT Rating (RTFE SEAT)

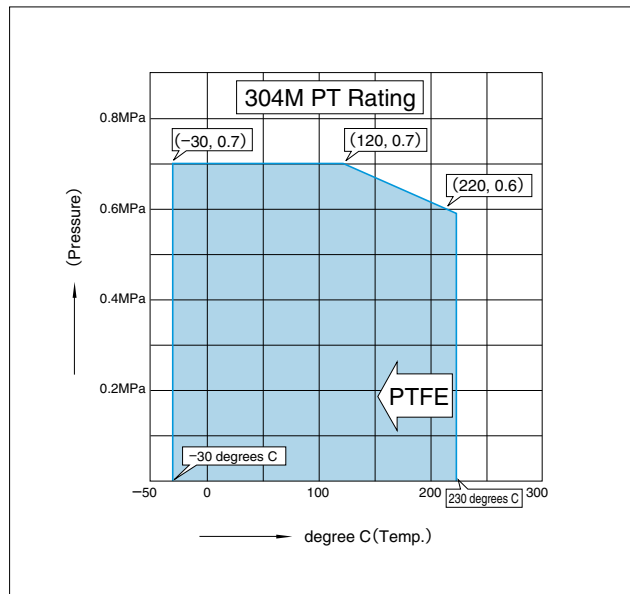

※No actuator extension bonnet is required.

304M Cv Value

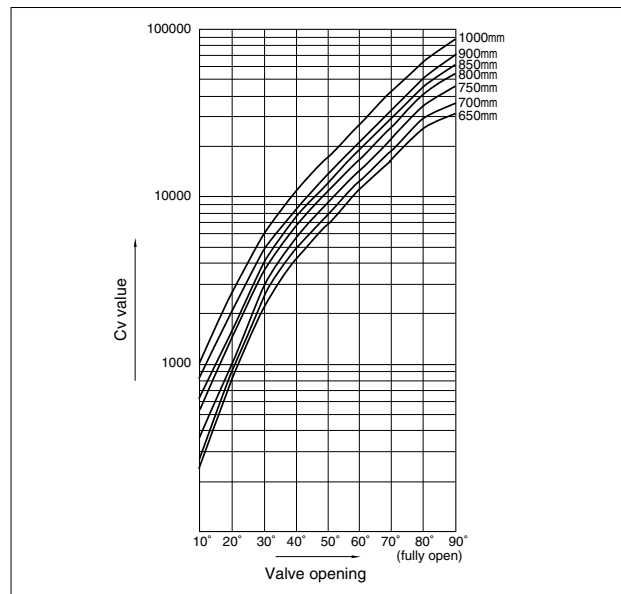

Standard Specifications

Valve model	304M	
Valve size	650, 700, 750, 800, 850, 900, 1000mm	
Face to face dimensions	Manufacturer's standard	
Applicable flange standard	JIS 5K, 10K, ASME B16.47 Class 150 Series A or B, DIN/BS NP/PN10	
Standard materials	Body	Carbon steel casting (SCPH2/WCB) with Mn3 (PO4) 2 treatment, Stainless steel casting (SCS13A/CF8, SCS14A/CF8M)
	Disc	Stainless steel casting (SCS13A/CF8 with Cr.plating, SCS14A/CF8M with Cr. plating)
	Stem	Stainless steel type 431, 630, 316
	Seat	RPTFE
	Gland packing	Carbon graphite
Max.working pressure*	0.7MPa (0.2MPa on non-preferred direction)	
Working temperature range*	-30 to 230 degrees C	
Seat leakage	Working pressure x 1.1 times (Max 0.8Mpa)	
Flow direction	Flow to shaft side is recommended.	
Marking	API609/MSS-SP25/JIS B 2004	
Piping flange gasket	Serrated spiral 45 to 55 groove/inch for gasket face finish, unless otherwise specified	

*Recommended piping position: shaft horizontal position

*Max. working pressure & temperature range are subject to change depending on customized specifications.

※It is possible that seat leakage occur when fluid (e.g. powder and/or liquid) is solidified by working temperature and other cause. Consult us. Please note that use with vertical line such as bottom area of discharge spout of hopper, and tank.

Butterfly Valve
TRITEC
TT2
334A
302A/303Q
304A/304Q
302Y/304Y
304M (HLV)
507V/508V
DTM
846T/847T/847Q
841T/842T
700Z
700G/704G/705G
700GB
731P/732P/732Q/752W
71LG
700E/700K/700S
704G/722F/720F
KRV
227P
907H/908H (MKT)
903C

HLV 304M

HLV 304M Principal dimensions

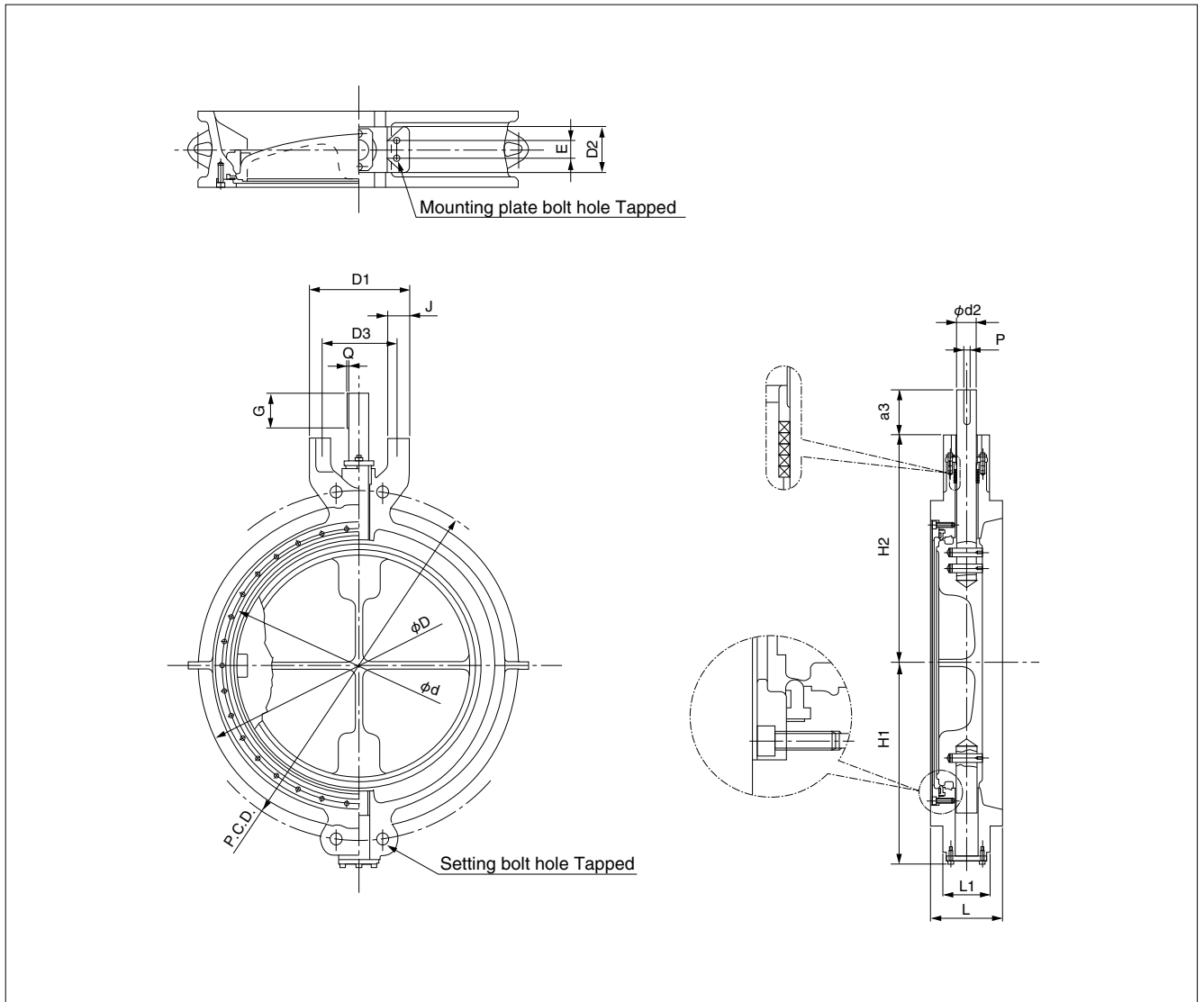

Nominal size		Dimension (mm)																Approx. Mass (kg)
mm	inch	d	D ^{*1}	L	L ₁	H ₁	H ₂	a ₃	d ₂	D ₁	D ₂	D ₃	E	J	G	P	Q	
650	26	653	739	165	105	459	520	117	45	230	105	175	40	50	79	14	3.5	218
700	28	702	789	165	132	510	560	145	55	430	132	380	90	55	121	16	4	285
750	30	754	843	180	132	546	690	145	60	430	132	380	90	55	121	18	4	365
800	32	801	893	190	132	579	705	145	60	430	132	380	90	55	121	18	4	407
850	34	853	943	203	143	591	720	175	65	430	143	380	90	55	151	20	4.5	460
900	36	903	993	203	137	621	750	175	65	430	137	380	90	55	151	20	4.5	505
1000	40	1000	1093	216	148	676	800	175	70	430	148	380	90	55	151	20	4.5	730

* Indicates JIS 5K value.

HLV 304M Typical Actuator Selection Chart

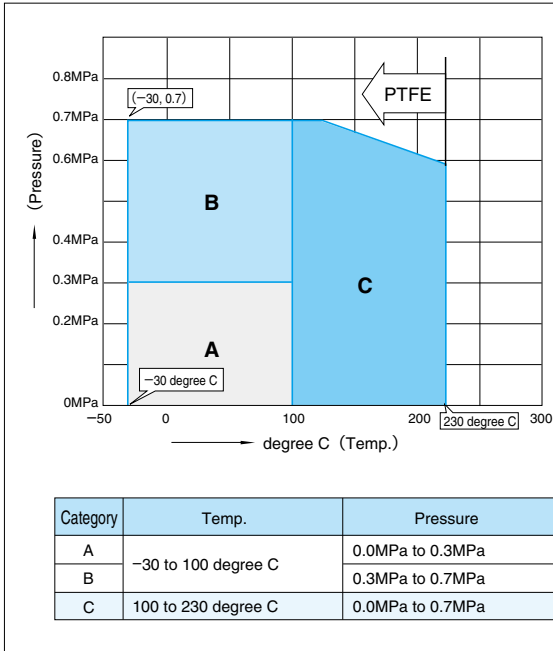

Size (mm)	650	700	750	800	850	900	1000
Category							

Worm gear 2S	A	MGH-4				MGH-4.5
	B	MGH-4.5		MGH-5		MGH-7
	C	MGH-4.5	MGH-5	MGH-6	MGH-7	On application

DA cylinder 3A	A	TGA-160			TGA-180
	B	TGA-180	TGA-200	TGA-220	TGA-250
	C	TGA-200	TGA-220	TGA-250	TGA-280

SA cylinder 3U, K	A	TG-20S			
	B	On application			
	C	On application			

Electric motor actuator is also available upon request.
Safety factor for above actuator selection table: 1.5 times
Actuator selection is subject to the actual working condition.

HLV 304M Applicable Flange Standards

Nominal size		Flange Standard									
mm	inch	JIS5K	JIS10K	ASME A	ASME B	DIN 10	BS	TAYLOR	LADISH	G5524	BS 10
650	26	○	○	○	○	—	—	△	△	×	×
700	28	○	○	○	○	○	○	△	△	△	×
750	30	○	○	○	○	—	○	△	△	×	△
800	32	○	○	○	○	○	○	△	△	△	×
850	34	○	○	○	○	—	—	△	△	×	×
900	36	○	○	○	○	○	○	△	△	△	△
950	38	—	—	○	○	—	—	△	△	×	×
1000	40	○	○	○	○	○	○	△	△	△	×

JIS5: JIS B2238(1996)
JIS10: JIS B2238(1996)

ASME A: ASME B16.47-1990 table5 dimensions of class 150 series A flanges
ASME B: ASME B16.47-1990 table11 dimensions of class 150 series A flanges
DIN 10: DIN3532 PN10

BS: BS4504 NP10

TAYLOR: TAYLOR FORGE 125, 150lb

LADISH: LADISH150

G5524: JIS G 5524

BS 10: BS10 TABLE E

○ : Applicable
△ : Applicable subject to conditions
— : Not standard
× : Not applicable

HLV 304M Minimum Internal Diameters of Piping

Nominal size		Minimum internal diameters of piping A (mm)
mm	inch	
650	26	612
700	28	653
750	30	705
800	32	754
850	34	803
900	36	834
1000	40	950

